

NOKIA 1506 Mediamaster

User Guide

NOKIA
CONNECTING PEOPLE



Quick guide

Satellite dish

The satellite dish must have an unobstructed path to the satellites.

Install the satellite dish according to the instructions.

If you already have a satellite dish installed, note that you will need a Universal LNB which works on the frequencies 10.70-12.75 GHz to be able to handle digital signals.

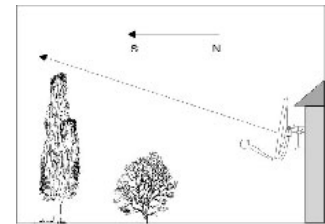

Connecting a TV and a VCR

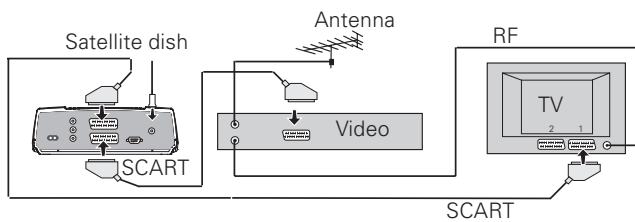

See pages 13 and 14 if you want to connect to an analogue satellite receiver or connect in any other way.

Preparing the Remote Control

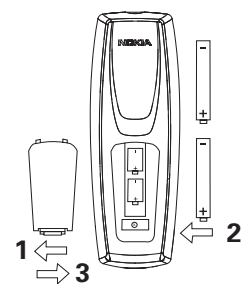

Switching on for the first time

- Plug in your Mediamaster.
- The "First time installation" menu is shown.
- Press the **select** button on the remote control to start the installation procedure.



Language

- Select the desired language from the menu using the **cursor up/cursor down** buttons.
This will also become the main language for audio and subtitling.
- Press **select** to continue.



Antenna/satellite selection

This Quick guide describes connection to the most common satellite dish installations that have one (1) Universal LNB.

- Select the "One antenna/one LNB configuration" alternative.
- Press **select** to continue.

If you have two or more LNBs connected to your satellite dish, see page 16.



Quick guide

One antenna/one LNB configuration

Select this alternative if you have **one (1) LNB** mounted on the antenna.

- Press **opt** to view the predefined channel.

LNB type

Select the correct LNB type for your configuration. The most common values, including Universal LNB, can be selected using the **cursor left/cursor right** button.

LNB offset voltage

If the cable from the antenna is very long, the voltage at the LNB could be too low to change the polarisation. You can increase the voltage to the LNB by 0.5 V.

Satellite

Select one of the pre-programmed satellites.

Predefined channel

Select one of the predefined channels and adjust the antenna until a TV picture from the predefined channel is visible in the background.

- Press **select** to confirm all settings and then carry out the channel search procedure.



Channel search

- Select the "Automatic search" alternative. Note that you can also choose to search only for free channels by selecting the "Automatic search for free channels" alternative.
- Press **select** to start the channel search. Note that you can choose to skip the channel search and select "Predefined channels". This alternative allows you to use only a few predefined channels that have been stored in the Mediamaster at the factory.

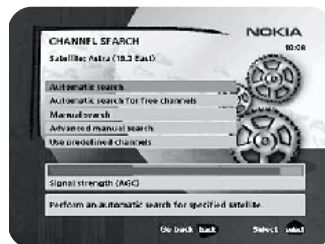

Channel search in progress

This menu will be shown while the Mediamaster is searching for TV and radio channels.

All channels that are found will be listed on the screen.

Please note that the search procedure may take a few minutes. You can cancel the search at any time by pressing **select**.

When the search procedure has ended, a message will tell you how many TV and radio channels have been found.

- Press **select** to continue.

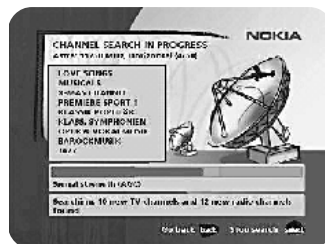

Time adjustment

The time is adjusted using the **cursor up/cursor down** buttons, \pm half an hour at a time. You can also change the minutes using the **cursor left/cursor right** buttons.

- Press **select** to finish the first-time installation and to open the Navi Bars.



Contents

Quick guide	3	Control folder ➤ Edit channels	21
Software end-user license	6	Control folder ➤ Edit satellites	24
General information	8	Control folder ➤ Timer	25
Remote control	9	Control folder ➤ System info	26
Front and rear panel	10	Settings folder ➤ Antenna	27
Installation of the Mediamaster	11	Settings folder ➤ Channel	27
Preparing the remote control	11	Settings folder ➤ TV	27
Connecting the Mediamaster to the dish	11	Settings folder ➤ Access ctrl	28
General	11	Settings folder ➤ Time	28
Connecting to the TV	12	Settings folder ➤ SW (software) update	29
Connecting a TV and VCR	12	Settings folder ➤ Reinstall	29
Connecting an analogue satellite receiver and a VCR	12	Satellite specific folders	29
Nokia smart switch	12	Games folder	29
Connecting a HiFi system	13	Viewing mode	30
First time installation	14	General information	30
General information	14	Programme information	30
The "First time installation" menu	14	Extended programme information	31
Language	14	Temporary settings	31
Antenna/satellite selection	14	External equipment	32
One antenna/one LNB configuration	15	Teletext	32
Multisatellite/DiSEqC switch configuration	15	Glossary of terms	33
Motor antenna configuration	17	Troubleshooting	34
Channel search	18	Technical specifications	35
Channel search in progress	19	Menus screen structure	36
Time adjustment	19		
Navi Bars	20		
General information	20		
The "Control" and the "Settings" folders	20		
Control folder ➤ User pref	21		

Nokia, Nokia Connecting People and Navi Bars are registered trademarks of Nokia Corporation. Other product names mentioned herein may be tradenames of their respective owners.

Nokia operates a policy of continuous development. Therefore we reserve the right to make changes and improvements to any of the products described in this manual without any prior notice.

Copyright © 2003 Nokia.

All rights reserved.



Nokia Mediamaster software end-user license

IMPORTANT: READ CAREFULLY BEFORE OR USING THE SOFTWARE NOKIA CORPORATION, NOKIA HOME COMMUNICATIONS END-USER SOFTWARE AGREEMENT

This Software Agreement (“Agreement”) is between You (either an individual or an entity), the End User, and Nokia Corporation, Nokia Home Communications (“Nokia”). The Agreement authorizes You to use the Software specified in Clause 1 below and which is included in this Nokia digital TV receiver. This is an agreement on end-user rights and not an agreement concerning sale.

Read this Agreement carefully before using the Software. By using this Nokia digital TV receiver, You agree to the terms and conditions of this Agreement. If You do not agree to all of the terms and conditions of this Agreement, return this Nokia digital TV receiver and accompanying documentation to the place of purchase. **YOU AGREE THAT YOUR USE OF THE SOFTWARE ACKNOWLEDGES THAT YOU HAVE READ THIS AGREEMENT, UNDERSTAND IT, AND AGREE TO BE BOUND BY ITS TERMS AND CONDITIONS.**

1. **SOFTWARE.** As used in this Agreement, the term “Software” means, collectively: (i) the software product identified above (ii) digital images, stock photographs, clip art, or other artistic works (“Stock Files”) (iii) related explanatory written materials and any other possible documentation related thereto (“Documentation”); (iv) fonts, and (v) upgrades, modified versions, updates, additions, and copies of the Software, if any, licensed to You by Nokia under this Agreement.

2. **END-USER RIGHTS AND USE.** Nokia grants to You non-exclusive, non-transferable end-user rights to use the Software on this Nokia digital TV receiver only.

3. **LIMITATIONS ON END-USER RIGHTS.** You may not copy, distribute, or make derivative works of the Software except as follows:

(a) You may transfer all your rights to the Software at the same time as You transfer this Nokia digital TV receiver on a permanent basis, provided that You transfer this Nokia digital TV receiver and all copies of the related Documentation, do not retain any copies by yourself, and the recipient agrees to the terms and conditions of this Agreement.

(b) You may not use, modify, translate, reproduce, or transfer the right to use the Software or copy the Software except as expressly provided in this Agreement.

(c) You may not resell, except as set forth in clause 3 (a), sublicense, rent, lease, or lend the Software.

(d) You may not reverse engineer, decompile, disassemble, or otherwise attempt to discover the source code of the Software (except to the extent that this restriction is expressly prohibited by law) or create derivative works based on the Software.

(e) Unless stated otherwise in the Documentation, You shall not display, modify, reproduce, or distribute any of possible the Stock Files included with the Software. In the event that the Documentation allows You to display the Stock Files, You shall not distribute the Stock Files on a stand-alone basis, i.e., in circumstances in which the Stock Files constitute the primary value of the product being distributed. You should review the “Readme” files (if any) associated with such Stock Files that You use to ascertain what rights You have with respect to such materials. Stock

Files may not be used in the production of libelous, defamatory, fraudulent, infringing, lewd, obscene, or pornographic material or in any otherwise illegal manner. You may not register or claim any rights in the Stock Files or derivative works thereof.

(f) You agree that You shall only use the Software in a manner that complies with all applicable laws in the jurisdiction in which You use the Software, including, but not limited to, applicable restrictions concerning copyright and other intellectual property rights.

4. **COPYRIGHT.** The Software and all rights, without limitation including proprietary rights therein, are owned by Nokia and/or its licensors and affiliates and are protected by international treaty provisions and all other applicable national laws of the country in which it is being used. The structure, organization, and code of the Software are the valuable trade secrets and confidential information of Nokia and/or its licensors and affiliates. You must not copy the Software

5. **COMMENCEMENT & TERMINATION.** This Agreement is effective from the first date You use this Nokia digital TV receiver. You may terminate this Agreement at any time by returning, at Your own costs, this Nokia digital TV receiver, and all related materials provided by Nokia. Your end-user rights automatically and immediately terminate without notice from Nokia if You fail to comply with any provision of this Agreement. In such an event, You must immediately return at Your own cost, this Nokia digital TV receiver, and all related material to the place of purchase.

6. **NO OTHER OBLIGATIONS.** This Agreement creates no obligations on the part of Nokia other than as specifically set forth herein.

7. **LIMITATION OF LIABILITY.** TO THE MAXIMUM EXTENT PERMITTED BY APPLICABLE LAW, IN NO EVENT SHALL NOKIA, ITS EMPLOYEES OR LICENSORS OR AFFILIATES BE LIABLE FOR ANY LOST PROFITS, REVENUE, SALES, DATA, OR COSTS OF PROCUREMENT OF SUBSTITUTE GOODS OR SERVICES, PROPERTY DAMAGE, PERSONAL INJURY, INTERRUPTION OF BUSINESS, LOSS OF

Nokia Mediamaster software end-user license

BUSINESS INFORMATION, OR FOR ANY SPECIAL, DIRECT, INDIRECT, INCIDENTAL, ECONOMIC, COVER, PUNITIVE, SPECIAL, OR CONSEQUENTIAL DAMAGES, HOWEVER CAUSED AND WHETHER ARISING UNDER CONTRACT, TORT, NEGLIGENCE, OR OTHER THEORY OF LIABILITY ARISING OUT OF THE USE OF OR INABILITY TO USE THE SOFTWARE, EVEN IF NOKIA OR ITS LICENSORS OR AFFILIATES ARE ADVISED OF THE POSSIBILITY OF SUCH DAMAGES. BECAUSE SOME COUNTRIES/STATES/JURISDICTIONS DO NOT ALLOW THE EXCLUSION OF LIABILITY, BUT MAY ALLOW LIABILITY TO BE LIMITED, IN SUCH CASES, NOKIA, ITS EMPLOYEES OR LICENSORS OR AFFILIATES' LIABILITY SHALL BE LIMITED TO U.S. \$50.

Nothing contained in this Agreement shall prejudice the statutory rights of any party dealing as a consumer. Nokia is acting on behalf of its employees and licensors or affiliates for the purpose of disclaiming, excluding, and/or restricting obligations, and liability as provided in this clause 7, but in no other respects and for no other purpose.

8. EXPORT CONTROL. The Software, including technical data, includes cryptographic software subject to export controls under the U.S. Export Administration Regulations ("EAR") and may be subject to import or export controls in other countries. The EAR prohibits the use of the Software and technical data by a Government End User, as defined hereafter, without a license from the U.S. government. A Government End User is defined in Part 772 of the EAR as "any foreign central, regional, or local government department, agency, or other entity performing governmental functions; including governmental research institutions, governmental corporations, or their separate business units (as defined in part 772 of the EAR) which are engaged in the manufacture or distribution of items or services controlled on the Wassenaar Munitions List, and international governmental organizations. This term does not include: utilities (telecommunications companies and Internet service providers; banks and financial institutions; transportation; broadcast or entertainment; educational organizations; civil health and medical organizations; retail or wholesale firms; and manufacturing or industrial entities not engaged in the manufacture or distribution of items or services controlled on the Wassenaar Munitions List.)" You agree to strictly comply with all applicable import and export regulations and acknowledge that You have the responsibility to obtain licenses to export, re-export, transfer, or import the Software. You further represent that You are not a Government End User as defined above, and You will not transfer the Software to any Government End User without a license.

9. CONTACT DETAILS. If You want to contact Nokia in respect of this Agreement, contact Nokia at the following address:

Nokia Home Communications
Itämerenkatu 11-13
00180 Helsinki
FINLAND

10. APPLICABLE LAW & GENERAL PROVISIONS.

This Agreement is governed by the laws of Finland. All disputes arising from or relating to this Agreement shall be settled by a single arbitrator appointed by the Central Chamber of Commerce of Finland. The arbitration procedure shall take place in Helsinki, Finland in the English language. If any part of this Agreement is found void and unenforceable, it will not affect the validity of the balance of the Agreement, which shall remain valid and enforceable according to its terms. This Agreement may only be modified in writing by an authorized officer of Nokia.

This is the entire agreement between Nokia and You relating to the Software, and it supersedes any prior representations, discussions, undertakings, end-user agreements, communications, or advertising relating to the Software.

General information about the Mediamaster

Throughout this manual you will notice that the everyday operation of your Mediamaster is based on a series of user friendly on-screen displays and menus. These menus will help you get the most from your Mediamaster, guiding you through installation, channel selection, viewing and many other functions.

All functions can be performed using the buttons on the remote control, and some functions can also be carried out using the buttons on the front panel.

Please be aware that new software may change the functionality of the Mediamaster.

Should you experience any difficulties with the operation of your Mediamaster, please consult the relevant section of this manual, including the Troubleshooting section, or alternatively call your dealer or a customer service adviser.

IMPORTANT! Please read this before using the Mediamaster!

- Allow 10 cm space around the Mediamaster for sufficient ventilation.
- Do not cover the Mediamaster's ventilation openings with items such as newspapers, table-cloths, curtains etc.
- Do not place the Mediamaster on top of a unit that emits heat.
- Do not place naked flame sources, such as lighted candles, on the Mediamaster.
- Use a soft cloth and a mild solution of washing-up liquid to clean the casing.
- Do not expose the Mediamaster to dripping or splashing liquids.
- Do not place any objects filled with liquids, such as vases, on the Mediamaster.
- To give your Mediamaster extra protection, e.g. during a thunderstorm, we recommend that you connect it via an external surge protection device.
- Do not connect or modify cables when the Mediamaster is plugged in.
- Do not remove the cover.
- Do not allow the unit to be exposed to hot, cold or humid conditions.
- Service should only be carried out at a Nokia Authorised Service Centre.
- Please note that the only way to completely isolate the Mediamaster from the mains supply is to unplug the mains cable!

Remote control

This section describes how to operate the Mediamaster using the buttons on the remote control. The standby button has double functionality. One function is performed if you gently press the button once and the other function is performed if you hold the button down for a few seconds.

Some of the functions can also be performed using the buttons on the front panel.

- ⏻** Press once to turn the sound off/on (mute). Press and hold for a few seconds to switch the Mediamaster in and out of standby mode.
- 0 - 9** Change the channel and select individual menu options.
Note: If 0 is entered as the first digit, the TV Release functionality is activated (see below).
- 0 □** To toggle between the Mediamaster and any external equipment connected to the AUX Scart, e.g. a video recorder or a satellite.
- info** To display short and extended information (if transmitted) about current and forthcoming programmes. Shows the viewing banner in viewing mode.
- back** Go back one level at a time within menus without storing any settings. To toggle between the current and previous TV/Radio channel in viewing mode. Close the Navi Bars.
- select** Confirm choices and the selection of a highlighted item. Open the Navi Bars.
- opt** Show service options in viewing mode.
- txt** Press to show teletext (if available).



The cursor button

Cursor up

Move up through the menus and change to the next channel in the current channel list while in viewing mode.

Cursor left

Move left/change settings in menus. Decrease the volume level while in viewing mode.

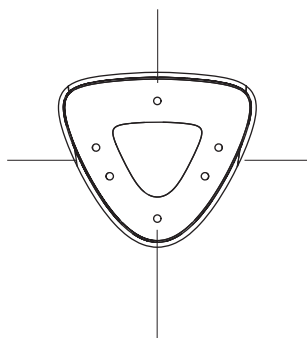

Cursor right

Move right/change settings in menus. Increase the volume level while in viewing mode.

Cursor down

Move down through the menus and change to the previous channel in the current channel list while in viewing mode.

FRONT AND REAR PANEL

Front panel

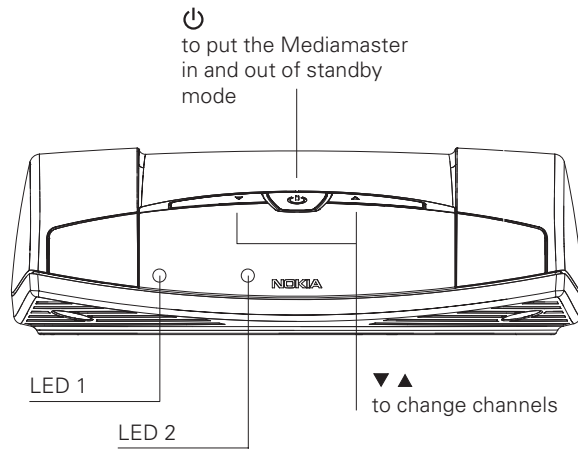

Function	LED indicator 1	LED indicator 2
ON	Green	-
Standby	Red	-
Locked to channel	-	Green (locked) / Red (not locked)
Remote control feedback	-	Single flash
SW download	Continous green flashing	Continous green flashing
Error	Continous red flashing	Continous red flashing

Rear panel

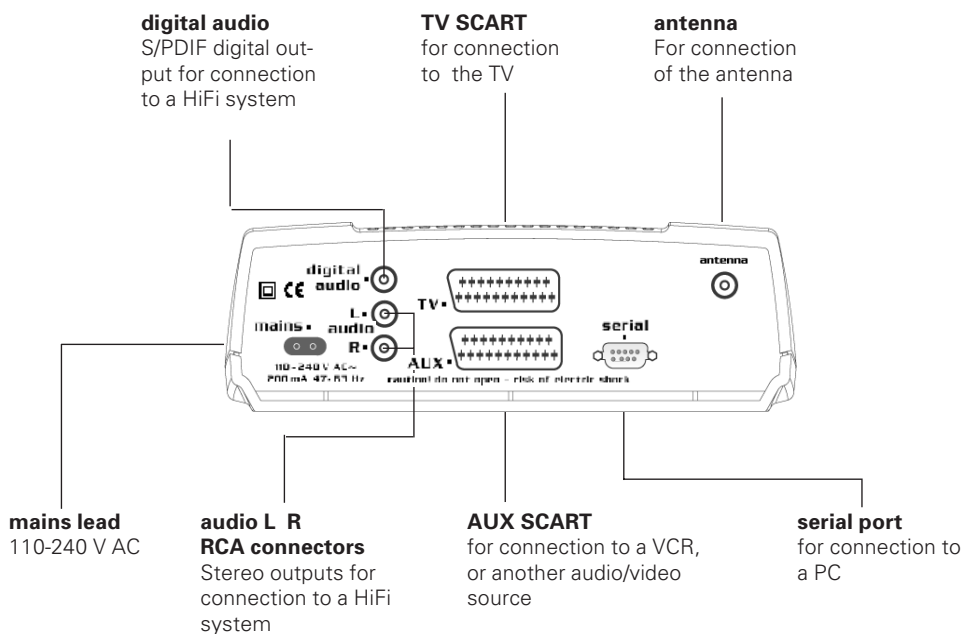

Installation of the Mediamaster

The Mediamaster box should contain the following items:

- the Mediamaster
- a remote control with 2 AAA batteries
- a SCART cable (fully connected 1.0 metre)
- a mains cable
- an owner's manual with the software license agreement

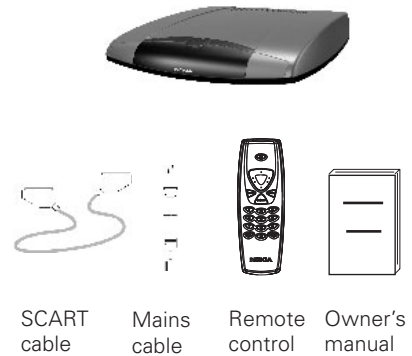

About the SCART sockets

The rear panel of the Mediamaster contains 2 **SCART** sockets (see diagram). When you connect other devices to any of these sockets, always **use fully connected SCART cables** (as supplied). There are "less well specified" SCART cables on the market and picture quality could be reduced if they are used.



SCART socket

Preparing the remote control

- Remove the cover from the battery compartment at the bottom of the remote control.
- Insert the 2 AAA (1.5 V) batteries, as shown in the diagram. Make sure that you observe the + and - markings indicated inside.
- Replace the cover.

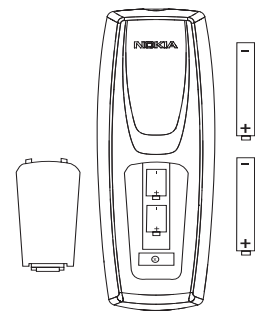

Connecting the Mediamaster to the dish

If you need to fit the F-connectors onto the cable

- Prepare each end of the cable as shown in the diagram. You will need to fold back the outer braid (as shown).
- Slide the F-connector onto the cable and then turn it clockwise until it grips the braid.
- Ensure that 3 mm of the core is protruding from the end of the connector.

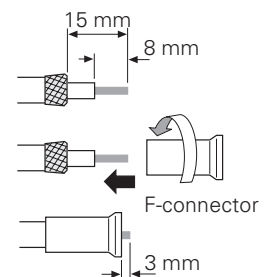

Installing the satellite dish

- See the Fitting instructions provided with your satellite dish on how to install the dish.
- Connect the coaxial cable, with the F-connectors fitted, from the LNB on the satellite dish to the socket marked "ANTENNA" on the rear panel of the Mediamaster.

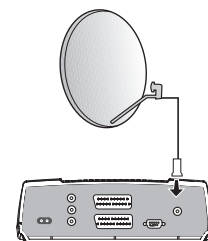

General

There are many different types of TV/VCR and other equipment that you can connect to the Mediamaster.

In this manual, you will see some of the most common ways to connect your equipment.

If you have problems with your connections and need help, please contact **your dealer**.

Installation of the Mediamaster

Connecting to the TV

- Connect the SCART cable between the main SCART socket on the TV and the TV SCART socket on the Mediamaster.
- Connect the TV aerial to the TV.

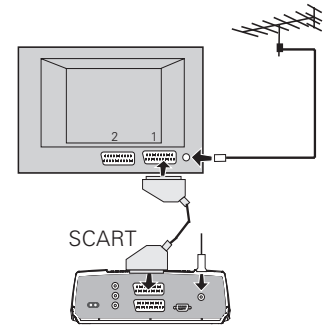

Connecting a TV and VCR

Refer to your VCR's manual for full instructions.

- Connect one SCART cable from the main SCART socket on the TV to the TV SCART socket on the Mediamaster.
- Connect another SCART cable from the VCR to the AUX SCART socket on the Mediamaster.
- Connect the RF cable from the RF output on the VCR to the TV aerial input on the TV.
- Connect the TV aerial to the RF input socket on the VCR.

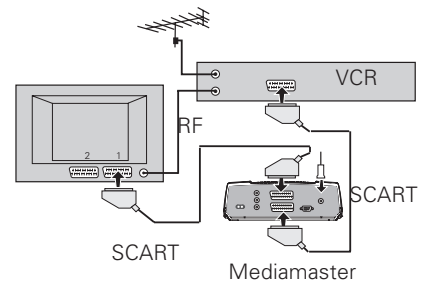

Connecting an analogue satellite receiver and a VCR

- Connect a SCART cable from the main SCART socket on the TV to the TV SCART socket on the Mediamaster.
- Connect a SCART cable from the VCR to the AUX SCART socket on the Mediamaster.
- Connect an RF cable from the RF output on the VCR to the TV aerial input on the TV.
- Connect an RF cable from the RF output on the analogue receiver to the RF input socket on the VCR.
- Connect the TV aerial to the RF input socket on the analogue receiver.

In order to switch the signal from the dish between the analogue and digital receivers, you will need a Nokia smart switch (at A B in the diagram) or a Universal Twin LNB.

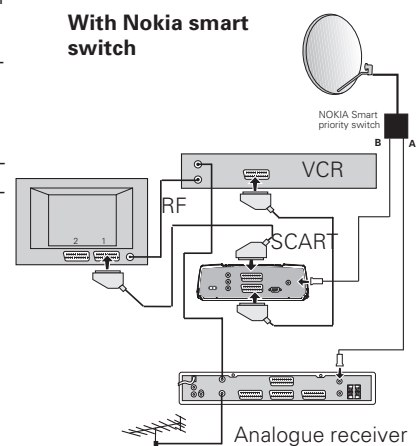

Nokia smart switch

- Connect a coaxial cable from output **A** on the smart switch (accessory) to the LNB socket **on the analogue receiver**.
- Connect a coaxial cable from output **B** on the smart switch to the ANTENNA socket **on the Mediamaster**.

The analogue receiver must be switched OFF (in standby mode) when you want to watch digital satellite channels from the Mediamaster.



Nokia smart switch

Installation of the Mediamaster

Connecting a HiFi system

- Connect an RCA stereo cable from the AUDIO L R sockets on the Mediamaster to the LINE, AUX, SPARE or EXTRA input sockets on your HiFi system.
- If available, you can connect a single RCA cable from the DIGITAL AUDIO socket on the Mediamaster to a HiFi system that is equipped with digital audio input. This output is also used for connecting to an external Dolby™ digital decoder.

Note: To avoid interference you must use a **screened** audio cable. Never connect digital output to any analogue input.

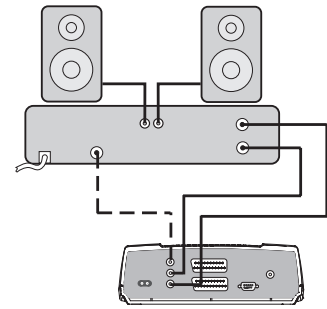

First time installation

General information

Once you have correctly connected the Mediamaster, you will also have to perform a "First-time installation." During this procedure, helpful information is displayed at the bottom of the menus.

Please note!

The **select** button always **confirms** a selection within these menus, and pressing it will take you to the next step in the installation process. However, and this is important, more than one value often has to be entered in a menu. Firstly, make all necessary setting changes. Then, confirm them all simultaneously by pressing **select**.

You can always return to the previous menu by pressing **back**.

Use the **cursor up/cursor down** button to move upwards and downwards from one line to another.

Use the **cursor left/cursor right** button to change settings.

You can also use the numeric buttons on the remote control to enter numeric values.

The "First-time installation" menu

This picture indicates that you have started the installation procedure.

- Plug in your Mediamaster.
- The "First-time installation" menu is shown.
- Press **select** to continue.



Language

- Select the desired menu language using the **cursor up/cursor down** button. This will also become the main language for audio and subtitling.
- Press **select** to continue.



Antenna/satellite selection

- Select the "One antenna/one LNB configuration" alternative if you have a single antenna equipped with one LNB for receiving signals.
- Select the alternative "Multisatellite/DiSEqC switch configuration" alternative if you have one antenna with two or four LNBs or two antennas with one or two LNBs each for receiving signals from a combination of satellites. In this cases you will need a 2-way or a 4-way DiSEqC switch.
- Select the "Motor antenna configuration" alternative if you have an antenna motor to control your satellite antenna.

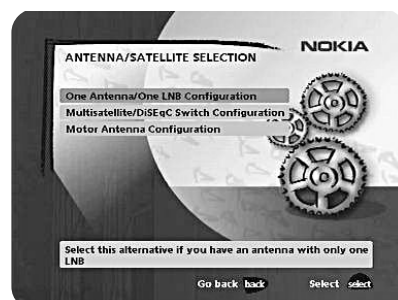

First time installation

One antenna/one LNB configuration

Select this alternative if you have **one (1) LNB** mounted on the antenna.

- Press **opt** to view the predefined channel.

LNB type

Select the correct LNB for your configuration. The most common values, including Universal LNB, can be selected using the **cursor left/cursor right** button.

LNB offset voltage

If the cable from the antenna is very long, the voltage at the LNB could be too low to change the polarisation. You can increase the voltage to the LNB by 0.5 V.

Satellite

Select one of the pre-programmed satellites.

Predefined channel

Select one of the predefined channels and adjust the antenna until a TV picture from the predefined channel is visible on the screen.

- Press **select** to confirm all settings and then carry out the channel search procedure.

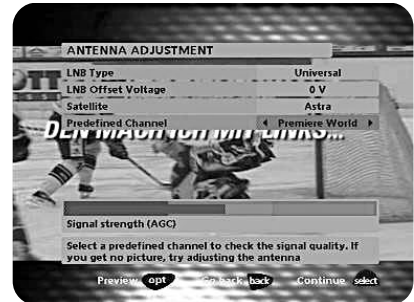

Multisatellite/DiSEqC switch configuration

Select this alternative if your antenna system **has more than one LNB**.

You can connect up to 4 LNBs. The selection of the different LNBs must be controlled by an external switch.

- Select the "DiSEqC 2 input switch" alternative if you have a 2-way DiSEqC switch.
- Select the "DiSEqC 4 input switch" alternative if you have a 4-way DiSEqC switch.
- Select the "Mini DiSEqC switch" alternative if you have a mini DiSEqC switch.

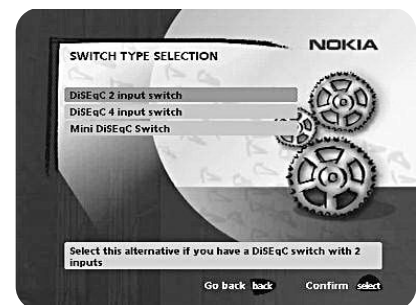

In this case you must first connect the LNBs to an external switch as there is only one antenna input on the Mediamaster. Once installed, the switch automatically selects the correct LNB for the selected channel.

This external switch is also known as a **DiSEqC™** switch. Since the switch can be located **close to the LNBs**, you only need **one** cable to connect to the Mediamaster.

First time installation

Typical connection of a two-way DiSEqC switch:

- Connect the cable from the LNB that is intended for channels from the ASTRA satellite (or THOR) to the connector marked LNB 1 (A) on the switch.
- Connect the cable from the HOTBIRD satellite (or SIRIUS) to the connector marked LNB 2 (B).
- Then, connect the antenna cable to the connector marked OUT on the switch.
- Connect the other end of this cable to the ANTENNA input at the rear of the Mediamaster.

For each LNB that you connect to the DiSEqC switch, the following configuration has to be carried out.

As an example, the following section will describe how the LNB intended for ASTRA will be configured for DiSEqC input 1 (A) on the switch and the LNB intended for HOTBIRD will be configured for DiSEqC input 2 (B).

Switch port

Select the input for each LNB that will be connected. In this example, the DiSEqC 1 input is selected first.

LNB type

Select the correct LNB type for your configuration, e.g. "Universal".

LNB Offset voltage

If the cable from any of the LNB's is very long, it might be necessary to increase the voltage to these LNB's by 0.5 V.

In most cases nothing needs to be altered here. Leave the default value as "0 V". If the switch does not change between horizontal and vertical polarisation, the voltage to an LNB can be increased later. Increase the voltage if an LNB does not change polarisation.

Satellite

In this example, select **ASTRA** because its LNB is connected to the **DiSEqC 1** input on the switch.

Predefined channel

Select one of the predefined channels and adjust the antenna until a TV picture from the predefined channel is visible on the screen.

- Press **opt** to view the predefined channel.

Repeat this procedure for the second DiSEqC port, but this time select **2** from "Switch port" and **HOTBIRD** as the satellite.

When the configuration of both DiSEqC ports has been completed, press **select**. A confirmation that the DiSEqC ports have been configured will show up. You can now start searching for channels.

- Press **select** to carry out the channel search procedure.

Please refer to the "Channel search" section on page 19.

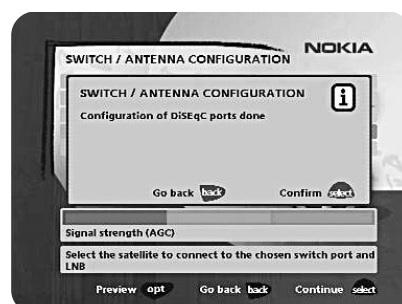
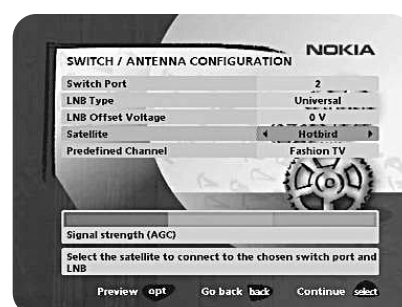
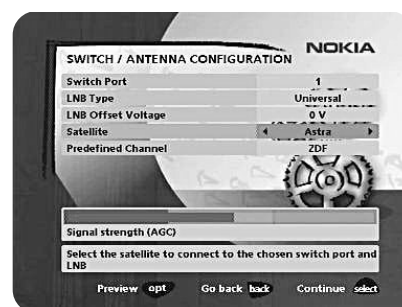
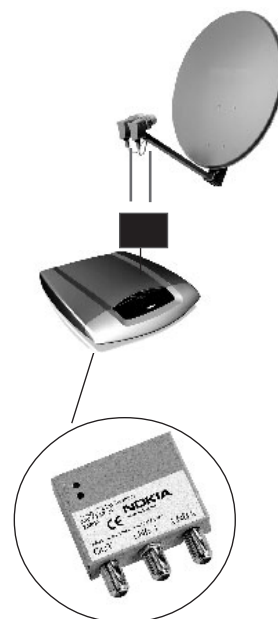

First time installation

Motor antenna configuration

If you have an antenna motor to control your satellite antenna you must configure the following settings.

- From the "Antenna/Satellite selection" menu select option 3 "Motor Antenna Configuration" and press **select**.

Type of motor

- Select SATSCAN (ASTRA) if you have a Nokia SatScan motor.
- Select DiSEqC (Hotbird) if the motor that you have is controlled by DiSEqC commands.

LNB type

- Select the correct LNB type for your configuration, e.g. "Universal".

LNB offset voltage

If the cable from the antenna is very long, the voltage to the LNB could be too low to change the polarisation. You can increase the voltage to the LNB by 0.5 V.

Predefined ASTRA-/HOTBIRD-channel

- Select one of the predefined channels and adjust the antenna until a TV picture from the predefined channel is visible on the screen.

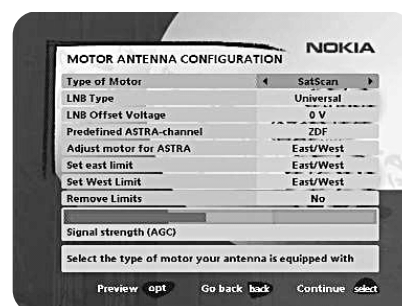

Adjusting the motor for ASTRA/HOTBIRD

To continue the installation you must now determine the angle to ASTRA 1 or HOTBIRD. The motor and the antenna must be adjusted towards the ASTRA 1 satellites at 19.2° East or HOTBIRD satellites at 13° East as this is the reference setting. All other pre-programmed satellite positions are oriented relative to ASTRA 1 or Hotbird.

You must also mount the antenna in a suitable location outdoors.

For more information, please read the separate installation instructions for the SatScan or DiSEqC positioner.

East and West limit set-up

Note! You **only** have to set one or both of these limits if the antenna is prevented from reaching its East/West limit positions. This could be the case, for example, if the antenna is mounted too close to a wall or in any similar situation.

To set these limits, adjust the antenna using the **cursor left/cursor right** button.

- Firstly, move the antenna to the east limit.
- Then move the antenna to the west limit.
- Press **select** to confirm all settings and carry out the channel search procedure.

First time installation

Remove limits

If you need to remove the limits.

When you activate this command, the motor will turn itself to the 0° (Zero) position.

However, the next time you select a channel, the motor will turn to its proper position.

Channel search

The Channel search procedure can be carried out in five different ways.

The menu will look different depending on what option you selected in the "Antenna/satellite selection" menu.

If you selected "One antenna/one LNB configuration", select "Automatic", "Manual" or "Advanced Manual" search, or "Use predefined channels".

If you selected "Multisatellite/DiSEqC switch configuration" or "Motor antenna configuration" you also indicate which satellite you wish to search from, using the **cursor left/cursor right** button.

Automatic search/Automatic search for free channels

If you selected "One antenna/one LNB configuration" or "Multisatellite/DiSEqC switch configuration":

- Press **select** to start searching for channels.

If you selected "Motor antenna configuration":

- Select a predefined channel and then adjust the motor (if necessary) using the **cursor left/cursor right** button.
- Press **select** to start searching for channels.

Manual search

The information that must be entered in this menu is available in satellite TV magazines or on the Internet.

Transponder frequency: Specify the frequency in MHz using the numeric buttons. If you enter the wrong value, erase using **cursor left**.

Polarisation: Select Horizontal, Vertical, Circular left or Circular right.

Symbol rate: Enter using the numeric buttons. If you enter the wrong value, erase using **cursor left**.

Network search: Select "Yes" if you want to search all transponders that are connected to a specific network.

Adjust motor: This alternative is only visible if you have set the motor antenna configuration. If necessary, adjust the motor for the current satellite.

- Press **select** to start searching for channels.

Video, Audio and PCR PID

These alternatives are only available if you are searching from a user-defined satellite. By entering these values you can see a TV picture on the screen which may help you to adjust the dish.

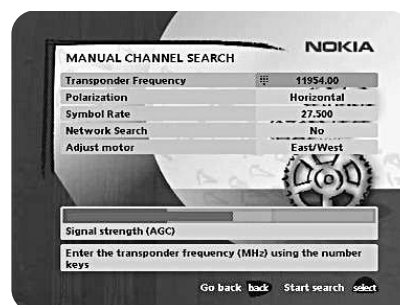
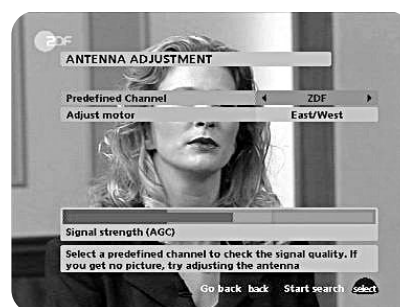
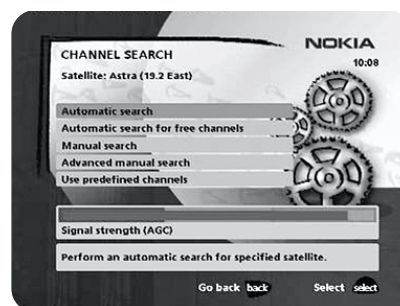
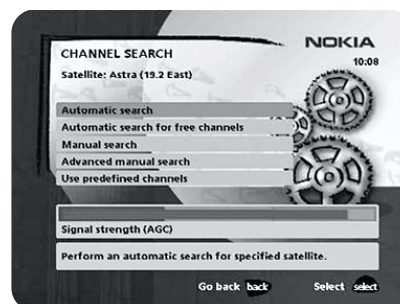

First time installation

Advanced manual search

The information that must be entered in this menu is available in satellite TV magazines or on the Internet.

You can use this menu if you are looking for some "special" channels (i.e. non-DVB standard channels) which can only be found when you have entered the necessary settings here.

Transponder frequency: Specify the frequency in MHz.

Polarisation: Select Horizontal, Vertical, Circular left or right.

Symbol rate: Enter symbol rate with the numeric buttons.

PID Video: Enter the PID (Packet Identifier) for the video signal.

PID Audio: Enter the PID for the audio signal.

PID PCR: Enter the PID for the PCR (Programme Clock Reference).

Adjust motor: This alternative will only be available if you have set the motor antenna configuration. If necessary, adjust the motor for the current satellite.

- Press **select** to tune in channels using the given parameters.

All channels that are located using the advanced manual search will automatically be given a generated name, for example, P0001 for the first channel, P0002 for the second, etc.

- Press **select** to save the new channel or **back** if you don't want to save it.

Use predefined channels

When you select this option, no channel search is performed and only predefined channels are used. You can also activate this function separately with the Navi Bars by selecting "Settings" and then "Channel", or by performing a reinstatement.

Channel search in progress

This menu will be shown while the Mediamaster is searching for TV and radio channels.

All channels that are found will be listed on the screen.

Please note that the search procedure may take a few minutes. You can cancel the search at any time by pressing **select**.

When the search procedure has ended, a message will tell you how many TV and radio channels have been found.

- Press **select** to continue.

Time adjustment

The time is adjusted by using **cursor up/cursor down**, $\pm 1/2$ an hour at a time. You can also adjust the minutes by using **cursor left/cursor right**.

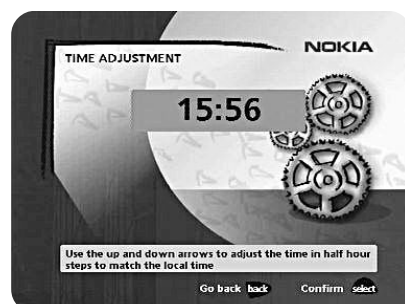
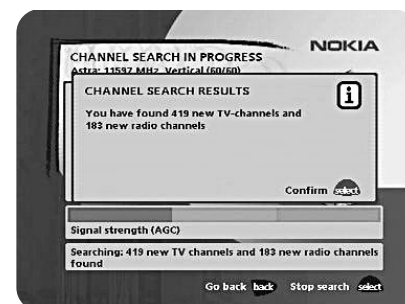
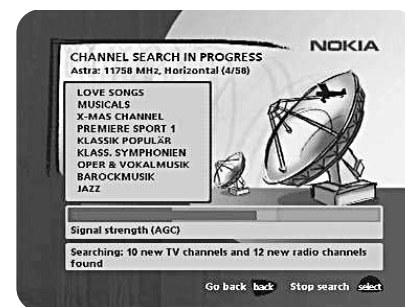
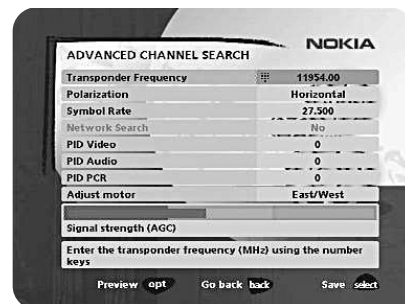

Navi Bars

General information

- Press **select** to open the Navi Bars.

The **Navi Bars** is used for selecting TV/Radio channels and changing system settings.

The horizontal row contains **folders**, for example, **Astra**, **Settings** and so on. Their names are shown in black text at the bottom of each folder.

Each folder contains **bookmarks**. The Control folder, for example, contains bookmarks for some system settings and so on.

You can move a folder horizontally by pressing the **cursor left/cursor right** button.

When a folder is brought into **focus**, the bookmarks are shown in a vertical row. The name of the different bookmarks are shown in white text at the top of each bookmark icon.

You can select a bookmark by pressing the **cursor up/cursor down** button. To confirm the selection, press **select**.

Below the folder bar some information about the bookmark that is currently in focus is shown in the information box. When a TV or radio channel bookmark is in focus, this box can contain three different symbols after the channel name.

(★ = a new channel you have not previously visited.)

📺 = the channel is scrambled according to the service information.

🔒 = the channel is locked by the user.)

While a TV or radio programme bookmark is in focus, you can obtain programme information by pressing **info**.

When you press **info** while a bookmark from the control or settings folders is in focus, you will obtain more detailed information about the functions of that menu.

When you press **opt**, you will obtain detailed channel information about the TV or radio programme bookmark that is in focus.

You can leave the Navi Bars at any time by pressing **back**.

If you open the Navi Bars and do not press any buttons on the remote control, the Navi Bars will automatically close after 2 minutes.

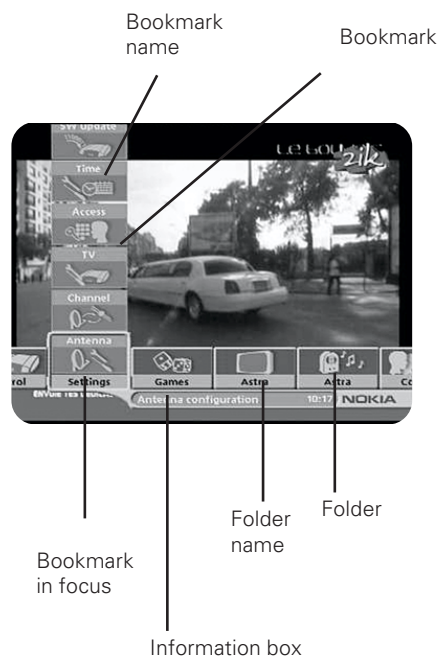

The "Control" and the "Settings" folders

Both of these system folders contains bookmarks. Each of these bookmarks contain menus from which you can configure different settings.

The system folders can not be deleted.

The different settings you can configure from the **Control** and **Settings** folders will now be explained, starting with the bookmarks in the **Control** folder.



Navi Bars

Control folder User preferences

Banner time-out

When you switch channels, an information banner will be shown for a few seconds. You can select the length of time that the banner will be shown.

Volume bar

Select whether or not you want the volume bar to appear on the screen when you change the volume.

Volume bar time-out

Select the length of time that the volume bar will be visible on the screen.

Subtitles

Select whether or not you want subtitles (if available) to be visible on the screen.

Main subtitle language

Select the preferred language for subtitling and event information. If the selected language is not available, no subtitling will be shown but the first available language for event information is selected.

Main audio language

Select the preferred language for audio. If this language is not available, the first available language is selected.

Menu language

Select the language for the menus.

Channel list icons

In order to make the bookmark lists for TV and Radio channels shorter, you can choose to hide the icons and only show the channel names. See the figure on the right.

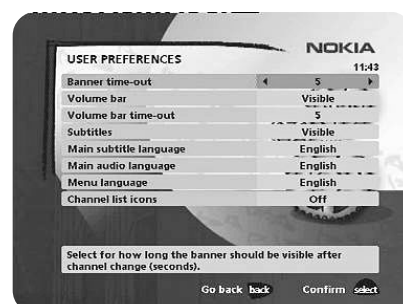

Visible



Invisible

Control folder Edit channels

Using these menus, you can create and edit favourite channel lists. You can add, delete, rename, and arrange the order of the channels on your favourite lists. The satellite lists may contain many channels. By creating your own favourite lists, you can make channel handling more convenient.

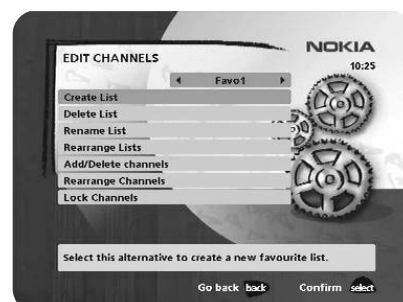

Navi Bars

Important information about editing channels

Before you start, you must select the list you want to edit. If you are watching TV and press **select** and then choose Edit channels, you can only edit TV channels. If you are listening to radio channels you can only edit radio channels.

After selecting the satellite specific TV or radio, use the **cursor left/cursor right** button to select the name of the list that you want to edit.

Create list

Before you start, you must select the satellite specific TV or radio list, that you want to use as a source list. This allows you to create your own favourite lists, containing the channels that you watch most frequently. There can be channels from different satellites in the same favourite list. You must give each list a specific name, for example, "Sport" or "Films". The new lists that you create will appear as a new folder in the horizontal part of the Navi Bars.

When a favourite list is selected, you will only see the names of the channels that are defined in the list.

When you have given the list a name; press **select** and choose "Add/Delete Channels" from the menu.

You can create up to eight separate favourite lists for TV and radio channels.



How to enter a specific name

This procedure is the same whether you enter a name for the first time or change an existing name.

- Move to a new character position using the **cursor left/cursor right** button.
- If you make a mistake, you can remove characters to the left of the cursor by pressing **txt** as many times as needed.
- Enter the name as follows:

Press the numerical button that corresponds to the character that you want: once for the first character, twice for the second, and so on.

The available characters are listed below.

1	*#&%=,;!;-+/\\$@^1	6	m n o 6 Ö Õ Ñ Ó Ò
2	a b c 2 Å Ä Á Â Ã Ä Æ	7	p q r s 7 \$
3	d e f 3 É Ê Ë Ì	8	t u v 8 Ü Ù Ú
4	g h i 4 î ï ð	9	w x y z 9
5	j k l 5	0	space and 0

- If the next letter is located on the same key as the present one, wait for the time-out or press the **cursor right** button to move one position and then select the letter.
- Toggle between capital and lowercase letters by pressing the **opt** button.
- To insert a space, press the button numbered **0**.

Navi Bars

Delete list

If you want to delete a Favourite list, select the list using the **cursor left/cursor right** button and press **select**.

Rename list

You can give an existing list a new name by following the instructions in the "**How to give a specific name**" section on page 19.

Rearrange lists

If you have created several Favourite lists, you can determine the sequence in which the lists will appear.

- Using the **cursor right** button, mark the list that you want to move to a new position.
- Move the list to the desired position using the **cursor up/cursor down** button and press **cursor left**.
- Press **select** to confirm the new position.

Add/Delete channels

From this menu, you add and remove channels in your Favourite list. Use the satellite specific lists as a basis for your selection.

A channel is added to or removed from the list by pressing **info**. The square on the right/hand side of a line will be empty to denote a removed channel, and will contain an "x" for added channels. Three different symbols can be shown beside the channel name. (★ = a new channel that you have not previously visited. 📺 = the channel is scrambled according to the service information. 🔒 = the channel is locked by the user.)

- Move to the desired channel(s) using the **cursor up/cursor down** button.
- Press **opt** if you want to preview the channel.
- Add/remove a channel by pressing **info**.
- When you have finished, confirm the selections and exit the menu by pressing **select**.

Rearrange channels

From here you can arrange the order of the channels within your favourite list.

- Move to the desired channel(s) with **cursor up/down**.
- Press **opt** if you want to preview the channel.
- With **cursor right**, mark the channel you want to move to a new position within the list.
- Move the channel to the desired position with **cursor up/cursor down** and press **cursor left**.
- Press **select** to confirm the new position.

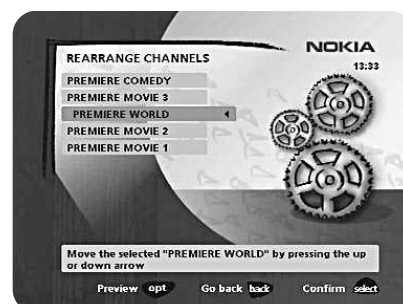
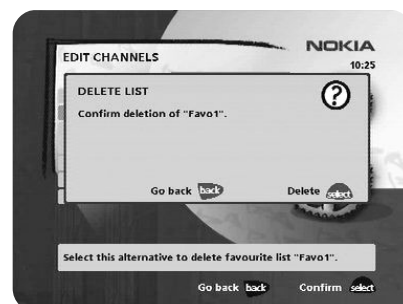



Navi Bars

Lock channels

To open this menu, you will be asked to enter your access code.

The access code is set to 1234 at the factory.

You can lock (and later unlock) channels on any of the lists in order to prevent, for example, your children from watching. Three different symbols can be shown beside the channel name. (★ = a channel that you have not previously visited.  = the channel is scrambled according to the service information.  = the channel is locked by the user.)

Select the channel that you want to lock or unlock and press **info**. Repeat the procedure for each channel that you want to lock. When you lock a channel on any list, the channel will automatically be locked on all other lists.

- Press **opt** if you want to preview the channel.

A locked channel will be indicated by a padlock symbol.

- Press **select** to confirm.

You must enter your access code before you can watch a locked channel.



Control folder Edit satellites

You can add a new satellite to the system. You can also edit or delete existing satellites.

To add a new satellite

- Select "Add Satellite".
- Enter the name of the new satellite. (Entering a name is described on page 23.)
- Enter the orbital position (in degrees) using the numeric buttons.
- Select an orientation, East or West.
- Press **select** to save these settings.



Before you can watch channels from that new satellite you must also carry out the following steps:

For a fixed antenna:

- Select "Antenna" in the Navi Bars.
- Follow the instructions on page 17 or 18. Select the new satellite name on line 3 (page 17) or 4 (page 18).
- Adjust the antenna towards the new satellite. **Please note:** With a user defined satellite you do **not** see a TV picture on the screen. When the Signal Strength is at its best:
- Press **select** to confirm the new settings.
- Press **back** to return to the Navi Bars.
- Select "Channel" in the Navi Bars.
- Select "Manual" or "Advanced" search.
- Enter the settings for the transponder frequency, polarisation etc. for the new satellite.

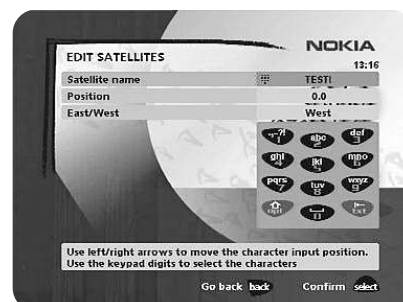

Navi Bars

- You can adjust the dish using channel preview if PID information has been entered.
- Press **select** to start the channel search.
- When you get the message on the screen that “you have found X new TV-channels and X new radio channels”, press **select** to save the new channels.

The new channels will be saved and added to the TV and radio lists.

When your antenna is controlled by a motor:

- Select “Channel” in the Navi Bars.
- Select “Manual” or “Advanced” search.
- Select the new satellite name.
- Enter the settings for the transponder frequency, polarisation, etc., for the new satellite.
- Adjust the antenna towards the new satellite using “Adjust motor”. **Please note:** With a user-defined satellite, you do **not** see a TV picture in the background of the screen. You can get a preview of the TV picture if PID information has been entered. Look at the signal strength (AGC) bar to check the signal. When the Signal strength is at its best:
- Press **select** to start the channel search.
- When you see a message on the screen that “you have found X new TV channels and X new radio channels”, press **select** to save the new channels.

The new channels will be saved and added to the TV and radio lists.

Edit Satellites

You can change the name, position and orientation of a user defined satellite. Predefined satellites can only be renamed.

Delete Satellite

You can only delete user-defined satellites.

When you delete a satellite, you also delete the channels that belong to it.

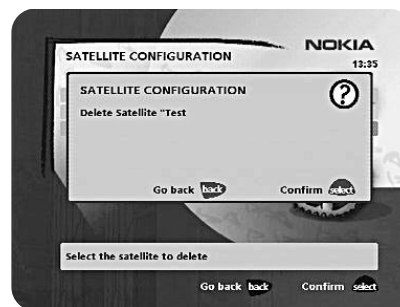

Navi Bars

Control folder Timer

General

You can program the Mediamaster to switch on and off at predefined times.

The timer function is very useful when you want to record a programme and you are unable to start/stop the recording event yourself, or when you just want to be reminded of the start of a programme that you do not want to miss.

Note! The timer function only works when the receiver is in standby mode.



Timer set-up

- First, select Channel List using the **cursor left /cursor right** button.
- Then, choose Channel to select the desired TV/Radio channel.
- Enter the date using the numerical buttons (yy/mm/dd).
- If you enter an incorrect digit, you can erase it using **cursor left**.
- Set the start and stop times using the numerical buttons.

The different start times can never overlap. If you try to enter a start or stop time within a period of time that is already occupied, you will receive a warning message.

- Press **select** to save the timer details or **back** to cancel.
- Press back twice to exit the Navi Bars and return to viewing mode.
- Press  to return the Mediamaster to standby mode.

Up to eight different timer events can be predefined. The events will be sorted in order of their start times.

You can erase a predefined event by pressing **cursor right**.

- Press **back** to cancel the deletion and **select** to delete the event.

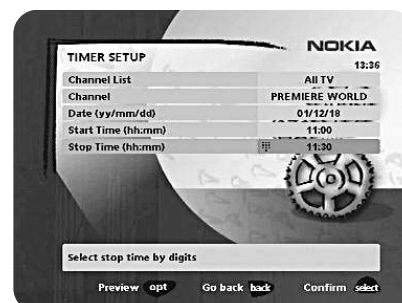

Control folder System info

If you need to contact your service provider or a service centre, they may ask for information that is available from this menu.

This gives general information about the hardware and software version on which your Mediamaster is running.

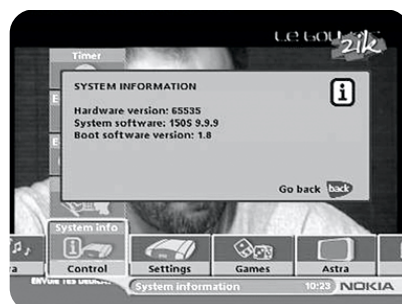

Navi Bars

Settings folder Antenna

To open this menu, you will be asked to enter your access code.

The access code is set to 1234 at the factory.

The procedure is performed in the same way as during the First- Time Installation. Please refer to page 15.

Settings folder Channel

To open this menu, you will be asked to enter your access code.

The access code is set to 1234 at the factory.

The procedure is performed in the same way as during the First- Time Installation. Please refer to page 19.

Update channels via a PC

On the Nokia web site (www.nokia.com) you can download a Windows™ software for updating the channel lists via the serial port. The **serial port** connector can be found on the back of the Mediamaster (see page 10) .



Settings folder TV

To open this menu, you will be asked to enter your access code.

The access code is set to 1234 at the factory.

You can adjust the audio/video settings for your receiver.

- Press opt to view the TV picture on the screen.

TV screen format

Select your TV screen format.

The 4:3 format is the standard format for most TV screens. Select 16:9 for a wide-screen TV.

Position of the RGB output

Adjust the horizontal position of the TV picture using the **cursor left/cursor right** button.

Set transparency level

Adjust the transparency level of the graphics in the menus using the **cursor left/cursor right** button.

Select digital audio format

Select an audio format for digital output (the upper audio output on the rear of the Mediamaster). Select AC-3 when the sound is transmitted in Dolby™ Digital format. Select PCM for ordinary digital sound. Please note: when you select AC-3, there will not be any sound output from the analogue audio connections.

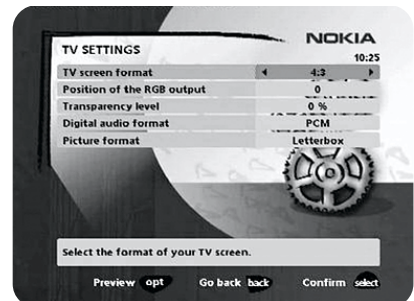

Navi Bars

Picture format

If you have a TV set with a 4:3 picture format and the transmission is 16:9, you can select "Fullscreen" or "Letterbox".

Fullscreen will fill the screen but some information on the left and right sides will be cut off.

Letterbox will give a complete picture, but black areas will be visible at the top and bottom of the screen.



'fullscreen'

'letterbox'

Settings folder Access

To open this menu you will be asked to enter your access code.

The access code is set to 1234 at the factory.

The following settings can be altered from this menu.

Access Control

Select "Yes" or "No" to turn the access control for all menus on or off. Note: Even when "No" has been selected, the access code must still be entered before you can watch locked channels.

Receiver lock

If you select "Yes" you will have to enter the access code every time you activate the Mediamaster from standby mode.

Age rating control

If you want everybody to have access to all available types of programmes, select "No"

If you select "Yes", you may block programmes that are unsuitable for children.

Age Limit

Select an age limit between 3 and 18 years on the line that appears.

However, you should be aware that not all Service Providers have implemented the necessary codes for these functions in their transmissions.

Change access code

You can change the access code from the standard factory setting of 1234. DO NOT FORGET YOUR ACCESS CODE! Without it, you will not have access to any of the functions that require the code!

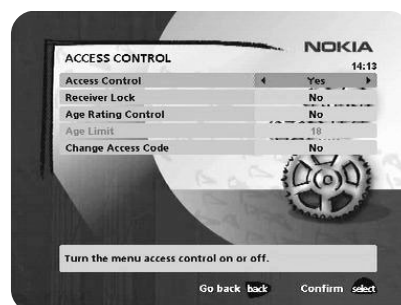

Settings folder Time

To open this menu, you will be asked to enter your access code.

The access code is set to 1234 at the factory.

The time is adjusted using the **cursor up/cursor down** button, half an hour at a time. You can also adjust the minutes using the **cursor left/cursor right** button.



Navi Bars

Settings folder ➔ SW (software) update

In order to keep the Mediamaster up-to-date, it will be possible to download new versions of the system software. New software may include new or improved features for existing menus.

Please check for the latest updates for your receiver at Nokia's website (www.nokia.com).

Enter this menu to check if a new software version is available.

IMPORTANT! Updating may take approximately 30 minutes. During the update the green LEDs on the Mediamaster front panel blink one at a time.

If you turn off the Mediamaster during the download procedure, the installation will continue when you turn on the Mediamaster again.



Settings folder ➔ Reinstall

To open this menu you will be asked to enter your access code.

The access code is set to 1234 at the factory.

Use this option **only** if you have to start the complete installation procedure from scratch. If you continue, **all** your previous settings, access code, favourite channels, etc, will be erased!

If you do not want to perform a reinstallation you can exit this menu when the warning is displayed by pressing back.



Satellite specific folders

When you select a satellite specific folder, for example, the Astra folder, and press a digit key on the remote control, a virtual keypad will appear on the screen. By entering characters in the field below the virtual keypad, using the digit keys on your remote control, you can specify the search for a specific channel.

When the search is complete and you tune in to the new channel by pressing select, the virtual keypad will disappear.

Games folder

- When the Games folder is in focus, select a game and press **info** to get instructions on how to play it.
- Press **select** to start a game.
- Press **back** to finish a game.



Viewing Mode

General information

The following describes the basic functions of your Mediamaster that can be used while watching satellite TV or listening to satellite radio.

Some of the functions described here are dependent on the Service Provider and can only be used if they are included in the transmitted programme information.

Please note that during the Channel Search procedure, the Mediamaster may download a large number of channels. This may include channels from various Service Providers, including those to which you do not have access unless you have a smart card from one of those Service Providers.

If you select a programme to which you do not have access, you will see a message on the screen. This message may vary depending on the Service Provider and the smart card/CA Module that you are using.

In addition to the normal functions such as switching the Mediamaster in/out of standby mode, changing the volume etc, there are other useful functions which will be explained in this part of the manual.

You can always exit a menu at any time, without affecting any settings, by pressing **back**.

If you are listening to a radio station and do not press any buttons on the remote control, the picture fades after 2 minutes.

Programme information

Every time you change channels, you will receive programme information for a few seconds. (In the "User preferences" menu of the Control folder, you can select the time period during which this information is shown.)

The information may include:

The current time.

A channel list.

The channel number and name.

The names of the current and next programmes.

The start and stop times of the current programme.

A bar indicating the elapsed time of the current programme.

The start and stop times of the next programme.

Programme information will only be available if it is included in the transmission. Otherwise a message stating "No information available" will be shown.

Channel number and name

Information about the current programme

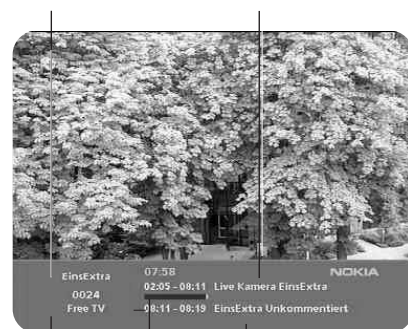

Current time

Information about the next programme

Channel list

Viewing Mode

Extended programme information

The Mediamaster can display information about programmes that are currently being broadcast as well as those that will be broadcast next.

This procedure is the same for both TV and radio mode.

By pressing **info** while watching TV the "Programme information" banner will appear. Press **info** again to display extended information about the current and the subsequent programmes. Use the **cursor left** / **cursor right** button to switch between the current and the subsequent programme information.

You cannot switch to another channel while the banner is visible.

When there is a large amount of information, use the **cursor up** / **cursor down** button to continue reading the next information page.

- Press **info** or **back** to return to TV/radio mode.



Temporary settings

By pressing **opt**, a menu opens which allows you to configure temporary settings. Settings changed in this "options menu" are only valid for the channel that you are currently watching. If you leave the channel and return to it later, the temporary settings will be deleted.

Audio language

If available, you can select from the different languages that are currently being broadcast.

Subtitle language

If available, you can select from different subtitle languages.

TV screen format

If you have a TV set with a 4:3 picture format, and the transmission is 16:9, you can select Fullscreen or Letterbox to change the display format. Fullscreen will fill the screen vertically, but some information from the left and right sides of the picture will be cut off. Letterbox will give a complete picture, but black areas will be visible at the top and bottom of the screen.

- Press **opt** or **back** to return to TV/radio mode.



Viewing Mode

External equipment

Use the **0 (zero)** button to toggle between the Mediamaster and any external equipment connected to the AUX Scart, e.g. a video recorder or a satellite receiver.

Teletext

Pressing **txt** will open a teletext page (if teletext is transmitted on that channel.) Select teletext pages using the numeric buttons on the remote control.

You can also quickly move to the different page options shown on any page by pressing the **cursor left/cursor right** button.

- After highlighting a page number, press **select** to go to that page.
- By pressing **"0"** you can alternate between the two pages that you just have most recently viewed.
- Press **info** to hide everything on a teletext page apart from its headline. See Figure 2.
- Sometimes a teletext page may contain subpages. When subpages are available, they are numbered on the lower part of the screen. See Figure 3. To view a subpage, press **select** when no page numbers have been highlighted. Move to the different subpages using the **cursor left/right** button. Please note: It may take some time before all subpages are available for selection.
- Press **txt/back** to return to TV/radio mode.

On most new TV sets, you can use the TV's remote control to open and control the teletext functions while watching digital TV channels. (The function is called VBI insertion.)



Figure 1

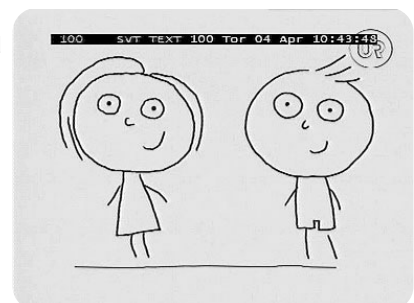

Figure 2



Figure 3. Subpage numbers

Glossary of terms

AC-3

A multichannel digital audio encoding system.

Access control

A feature that allows parents to "lock" programmes that they consider to be unsuitable for children. A "locked" channel or programme can only be "unlocked" using the special access code.

Access code

A four-digit code stored in the Mediamaster. It is used to lock/unlock the Mediamaster.

AGC

Automatic Gain Control.

AUX

Auxiliary.

BER

Bit Error Rate. A signal quality measure.

C/N

Carrier to Noise. Signal quality measure

DiSEqC

DiSEqC™ (Digital Satellite Equipment Control) system which is a communication bus between satellite receivers and peripheral equipment using only the existing coaxial cable.

DVB

The Digital Video Broadcast group, which was created to establish a technical framework for the introduction of digital video broadcasting systems.

GHz

GigaHertz. The prefix giga means milliard, and Hertz means cycles per second. Signals in the GHz range are often called microwaves.

LNB (low-noise block converter) or LNBF

An electronic unit mounted on a satellite dish. It receives the signals that are reflected by the dish and converts them to signals that can be used by the Mediamaster.

MHz

MegaHerz. The prefix mega means million, and Hertz means cycles per second.

MPEG

Moving Picture Experts Group. Established by the International Standards Organisation to provide the basis for a picture coding and compression system.

Network

A number of digital channels that are transmitted from one source. The networks are grouped under separate headings in the channel list.

PCM

Pulse Code Modulation. Non-compressed digital audio format.

PCR

Program Clock Reference.

PID

Packet Identifier.

Polarisation

Polarisation allows several programmes to fit into the same frequency band. The signals from a satellite are transmitted either with linear (vertical or horizontal) polarisation or circular (right or left) polarisation.

RCA

A coaxial connector used to connect the Mediamaster to an external amplifier.

RF

Radio frequency (known as HF in some countries).

RGB

Red, Green, Blue. Colour signals are routed through separate cables in order to provide a high-quality TV picture.

SatScan

SatScan is a one-cable positioning system, allowing reception of 29 different preprogrammed satellite positions within a range of 60 degrees.

SERIAL RS 232

A serial communication standard data port.

SCART

A 21-pin connector used for connecting the Mediamaster, VCR and TV. Also named Euroconnector or Peritel connector.

Scrambled TV programme

Some TV programmes are transmitted in scrambled form.

S/PDIF

Sony/Philips Digital Interface Format. Digital audio output.

Symbol rate

Speed of the digital transmission

SW

Software. Programme code.

TS

Transport stream.

VCR

Video Cassette Recorder.

Troubleshooting

Problem	Possible causes	What to do
The LED on the front panel does not light up/is not lit. The left-hand LED is red	The mains cable is not connected. The Mediamaster is in standby mode.	Check that the mains cable is plugged into the power socket. Press the standby button to take the Mediamaster out of standby mode.
No sound or picture.	The satellite dish is not pointing at the satellite. There is no signal or only a weak signal.	Adjust the dish. Check the signal level indicator in one of the channel search submenus. Check the cable connections, LNB, and other equipment that is connected to the LNB and the receiver, or adjust the dish.
No sound or picture on the horizontal modulated transponder.	The LNB is faulty.	Replace the LNB. If you have a long cable, increase the LNB voltage by 0.5 V using the Antenna/Satellite Configuration menu.
Bad picture/blocking error.	The satellite dish is not pointing at the satellite. The signal is too strong. The satellite dish is too small. LNB noise factor is too high. The LNB is faulty.	Adjust the dish. Connect a signal attenuator to the LNB input. Change to a larger dish. Change to an LNB with a lower noise factor. Change the LNB.
There is no Welcome menu on the screen after you have switched the Mediamaster on for the first time.	The system is connected by SCART cables and the TV is not in AV/EXT mode.	Switch the TV to the appropriate AV input.
You made a video recording from a digital satellite channel and the whole programme, or parts of it, were not recorded.	The Mediamaster was not left on the appropriate channel. The system is connected by SCART cables and the VCR is not in AV/EXT mode.	If you make a recording from a digital satellite TV channel, your Mediamaster must be left on the channel from which you want to record. Switch the VCR to appropriate the AV input.
The remote control is not working.	The batteries are exhausted. The remote control is incorrectly aimed. The Mediamaster is in standby mode.	Change both batteries. Aim the remote control at the box. Check that nothing is blocking the front panel. Check whether LED indicator 2 on the front panel is flashing when you press a button. If not, replace both batteries.
You have forgotten your secret access code.		Contact your dealer or Service Provider. They will help you set it up again.
In the software update state, both LEDs simultaneously blink red a few times before system start-up.	There is a software download error.	Try to update the software.
In the software download state both LEDs blink red alternatively.	There is no signal or only a weak signal.	Check the cable connections, LNB, and other equipment that is connected to the LNB and the receiver, or adjust the dish.
After the software update, or when you start-up your Mediamaster, both LEDs blink red simultaneously.	System failure.	Disconnect the mains cable. When you reconnect it, the Mediamaster will try to download new software from the satellite. Try to update the system software via serial cable connection. Contact your dealer.

In case your problem with Mediamaster does not match any of the above mentioned situations and you cannot solve it accordingly, try the following instructions:

Unplug and then plug in the mains cable.

- 1) If Mediamaster starts normally and works correctly, this is all you have to do.
- 2) When reconnected, the green LEDs blink one at a time. Wait! Keep the receiver connected to the mains outlet and the antenna. Mediamaster is trying to update the system software from a satellite. This may take thirty minutes.
- 3) If the receiver starts but you cannot enter the Settings/Reinstall through the Navi Bars, activate Reinstall by pressing all three buttons on the receiver front panel and keeping them down for three seconds. Note that Reinstall will reset ALL your previous settings and favorite lists. If you have tried all of the above actions without solving the problem, please contact your dealer or Service Provider.

Technical specifications

Transmission standards

DVB, MPEG 2

LNB / Tuner input

Connector	1x F-type (LNB)
RF input frequency	950-2150 MHz
RF input power level	-20 to -65 dBm
Supply voltage	13 /18 V \pm 5%
Max. current	500 mA, overload protected
Control voltage	22 kHz, 0.65 V _{pp}
DiSEqC	Tone burst A/B or Level 1.2
RF impedance	75 Ω

TV SCART

Video output	1 V _{pp} (\pm 1 dB) / 75 Ω
Audio output	0.5 V _{rms} / R _L >10 k Ω
RGB output	Internal RGB
RGB bandwidth	5.8 MHz \pm 3 dB
Fast blanking output	Internal or from AUX SCART
Status output	0/6/12 V / R _L 10 k Ω

AUX SCART

Video output	1 V _{pp} (\pm 1 dB) / 75 Ω
Video input	1 V _{pp} / 75 Ω
Audio output	0.5 V _{rms} / R _L >10 k Ω
Audio input	0.5 V _{rms} / R _L >10 k Ω
Status input	0/6/12 V / R _L >10 k Ω

DIGITAL AUDIO (S/PDIF)

Connector 1 x RCA

AUDIO R L

Connector 2 x RCA (R+L)
Output 0.5 V_{rms} \pm 0.5 dB/ R_L 10 k Ω

SERIAL (RS 232) serial data

Connector	9-pin D-sub male
Signals	RS232, max. 115.2 kbit/s
Pin 1 DCD	(Data carrier detect) not connected
2 RXD	(Receive data)
3 TXD	(Transmit data)
4 DTR	(Data terminal ready) Set to high
5 GND	(Signal ground)
6 DSR	(Data set ready) not connected
7 RTS	(Ready to send)
8 CTS	(Clear to send)
9 RI	(Ring indicator) not connected

Front panel

2 LEDs, Buttons: \odot , \blacktriangledown , \blacktriangle (standby, progr. number up and down)

General data

The model code, variant and serial number, are located on a label on the underside of the housing.

Supply voltage	110-240V AC, 47-63Hz
Power consumption max load	20 W at 500mA LNB
Power consumption in standby	5 W
Operating temperature	+5° C to +45° C
Storage temperature	- 40° C to +65° C
Humidity	25 to 90 % rel humidity
Operating distance for remote control	max 10 metres
Dimensions (w x d x h)	216 x 245 x 70 mm
Weight	750 g approx

SCART sockets

TV	AUX
1 Audio out right ch.	Audio out right ch.
2 -	Audio in right ch.
3 Audio out left ch.	Audio out left ch.
4 Audio ground	Audio ground
5 RGB blue ground	Ground
6 -	Audio in left ch.
7 RGB blue signal out	-
8 Switch voltage out	Switch voltage in
9 RGB green ground	Ground
10 Connect to pin 10 in AUX scart	
11 RGB green signal out	-
12 -	-
13 RGB red ground	Ground
14 Fast blank. ground	Ground
15 RGB red signal out	-
16 Fast blanking out	-
17 Video out ground	Video out ground
18 Ground	Video in ground
19 Video out	Video out
20 -	Video in
21 Ground (casing)	Ground (casing)



Menu screen structure

First time installation

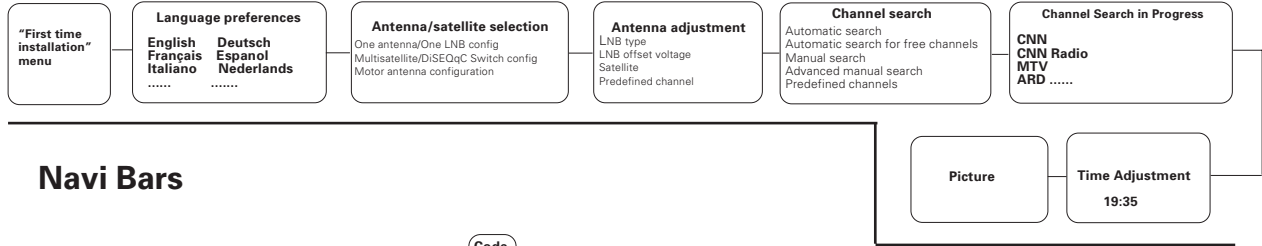

Navi Bars

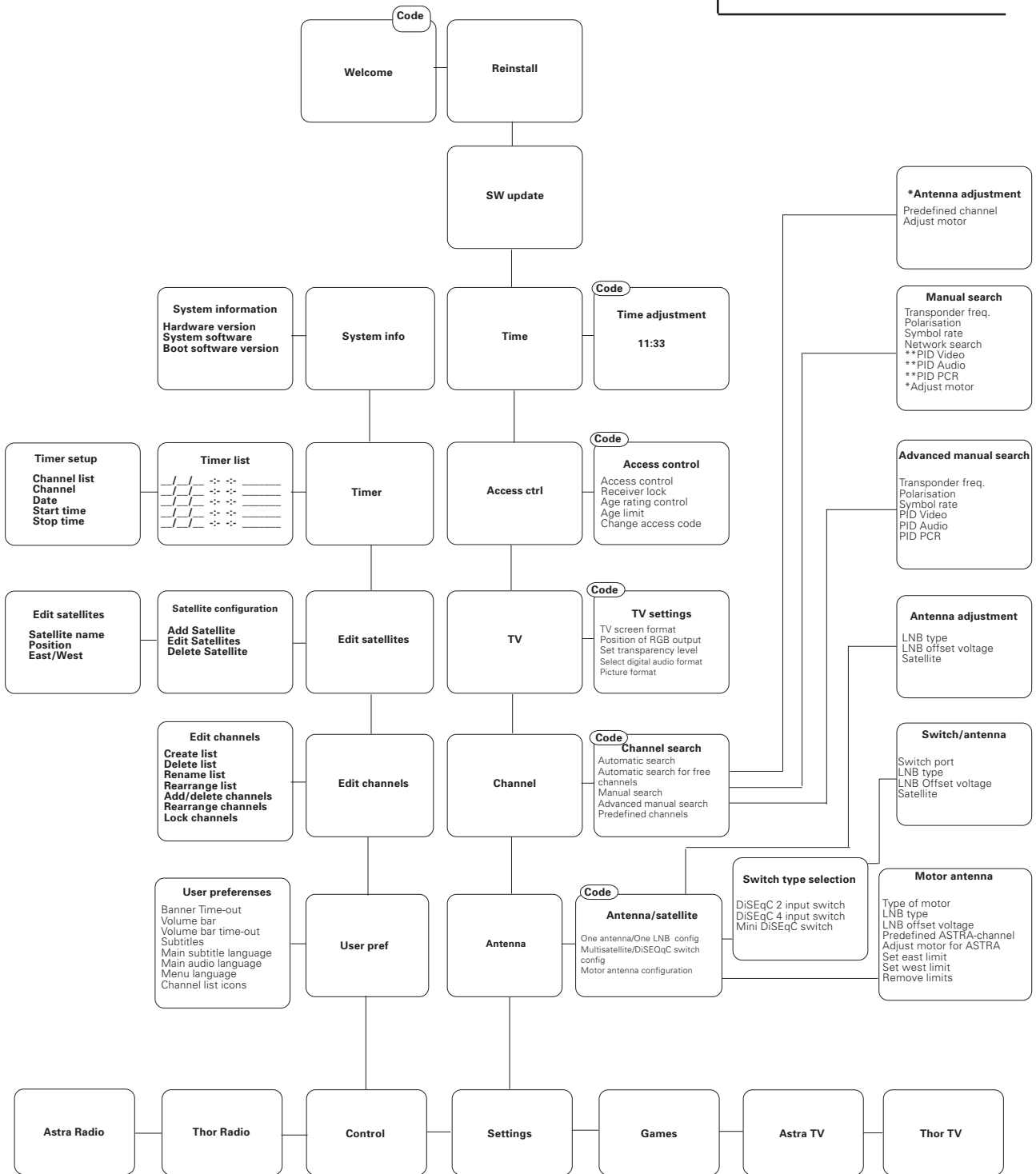

*Only visible if you made a motor antenna configuration.
**Only visible if you are searching a user defined



Nokia is a registered trademark of Nokia Corporation

www.nokia.com



00000935.00

